

**MOTOR | CHASSIS | SERVICE**



## MOTOR, CHASSIS, SERVICE – IN THE PC AND CV SECTORS

There will come a day when you start to see things as a whole – taught by your own experience.

There will come a day when you start to set your sights higher - driven by your own ambitions.

There will come a day when you start to realise that the sole criterion for quality is the quality itself and not the price.

At RUVILLE that day came more than 80 years ago.

We are still harnessing the power of these ideas today.

There is hardly a business segment relying more on trustworthy suppliers than the spare parts business. The sole gauge: OE quality.

Our declared goal: to be a flexible business partner and service provider who anticipates market needs and trends, and meets manufacturers' standards. That we have managed to achieve this goal is reflected in our collaborations with leading car makers, the RWTH Aachen University and Germanischer Lloyd.

Over the past years RUVILLE as a member of the Schaeffler Group has succeeded in establishing itself as a specialist provider of engine, chassis and service solutions in the PC sector – a market position we also strive to consolidate in the CV sector in 2009 by offering a wide range of application.

As your partner, we go way beyond supplying spare parts. Conservative as this may sound, it is actually a promise. As far as we are concerned, a promise is a promise – both at home in Hamburg and around the world.



Tension rollers  
keep the toothed belt tight  
and reduce running noise.



RUVILLE means quality. Consequently, our parts have to pass a series of internal and external tests before they are put into operation – be it as individual components or as kits.

Our customers can always rely on the excellent quality of our products: from T/U parts and kits, to our logistic services and practical training programs. And we always deliver on our promises. You have our word on it.



## PRECISION AND POWER: ENGINE PARTS

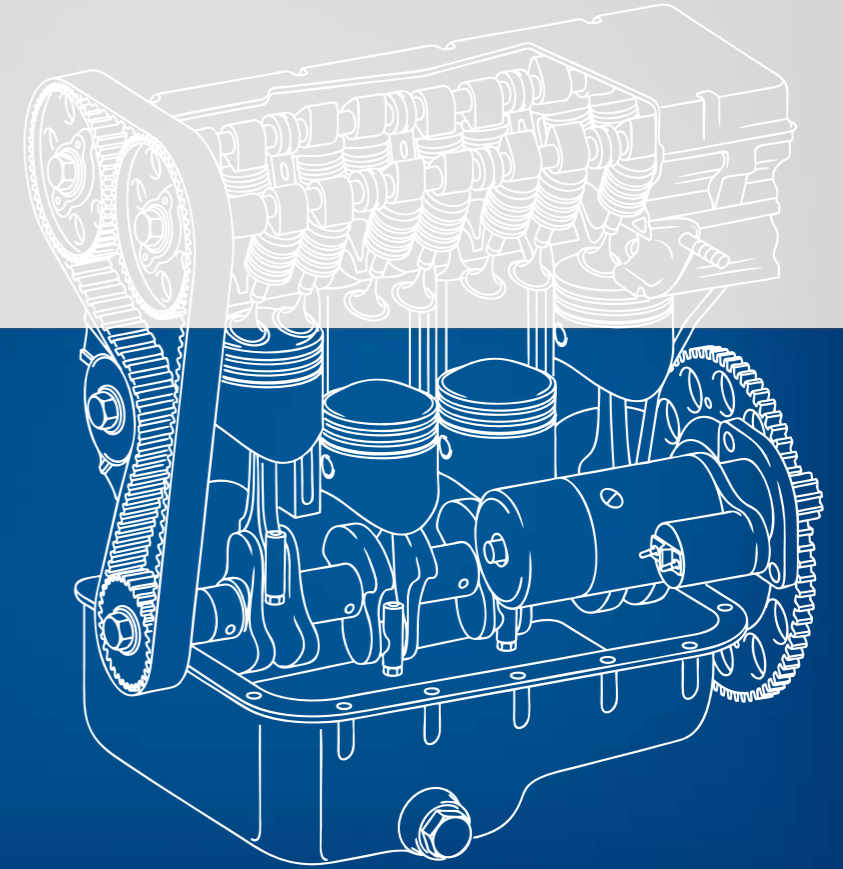

**SPARE PART COMPONENTS:  
PRECISION IN EVERY DETAIL  
REQUIRES FULL COMMITMENT.**



This control arm has been produced using the Cobapress process and exemplifies the state-of-the-art production methods in place at RUVILLE.

With the same meticulousness one would need to build a matchstick model of Hamburg's landmark – the St. Michaelis Church – our engineers scrutinize each spare part prior to purchasing it.

In so doing we make sure that RUVILLE parts meet our customers' demands for consistent product quality:

The chain drive is subjected to massive loads. Because each of the 56 links will travel more than 500,000 km throughout its service life.



**OUR KNOW-HOW  
TO DEVELOP A PERFECT KIT WE HAVE  
TO READ BETWEEN THE DESIGNS.**

The individual spare part is only the basis. To excel with bespoke full-service repair solutions, perfection and precision also have utmost priority during production.

To achieve this, we closely collaborate with the TÜV, Germanischer Lloyd and the RWTH Aachen Technical University. We thereby ensure that every RUVILLE part is at the cutting edge of technical development.

From axle bellows kits, engine and transmission mountings, strut mountings, wheel bearing sets and water pumps to steering and chassis components, and much more besides. RUVILLE parts embody technical expertise, right down to smallest nut.

Compelling cost-efficiency: the easy-to-install axial joint repair kit.



What comes next is, literally speaking, our part: using the most technically advanced automotive components we develop made-to-measure repair kits designed to ensure maximum compatibility, precise fitting and easiest installation.

We meet the growing market demand for product quality and reliability by earning certification for our key production and management processes. As a result, product quality is continuously improved – and our customers can be convinced that promises are followed by action.

By all means, inquire about our product quality study.



Quality raised to the power of seven: geared to the needs of the repair professional, water pump kits facilitate time and cost-efficient repair of the timing drive.

Perfection in detail – that's what distinguishes our CV chassis parts with galvanized finishing.



Consistent improvement has made our tension roller units even easier to handle – and simple to replace even when you're on the road.

## BIG COMPANIES HAVE TO THINK BIG. ENGINE PARTS FOR COMMERCIAL VEHICLES.

In the CV sector, too, we stand to capitalize on our meticulous commitment to detail. And once you get used to that, there's no going back. Besides tension rollers, our range of CV engine parts also includes water pumps.

But RUVILLE components also drive other parts of the vehicle. By adding steering components to our existing range of CV spare parts, we can supply every part you'll need to keep your truck running like a dream.

Keeps the cooling system up at 1.0–1.5 bar and saves up to 2% of fuel.



## FLEXIBLE AND DURABLE CHASSIS COMPONENTS

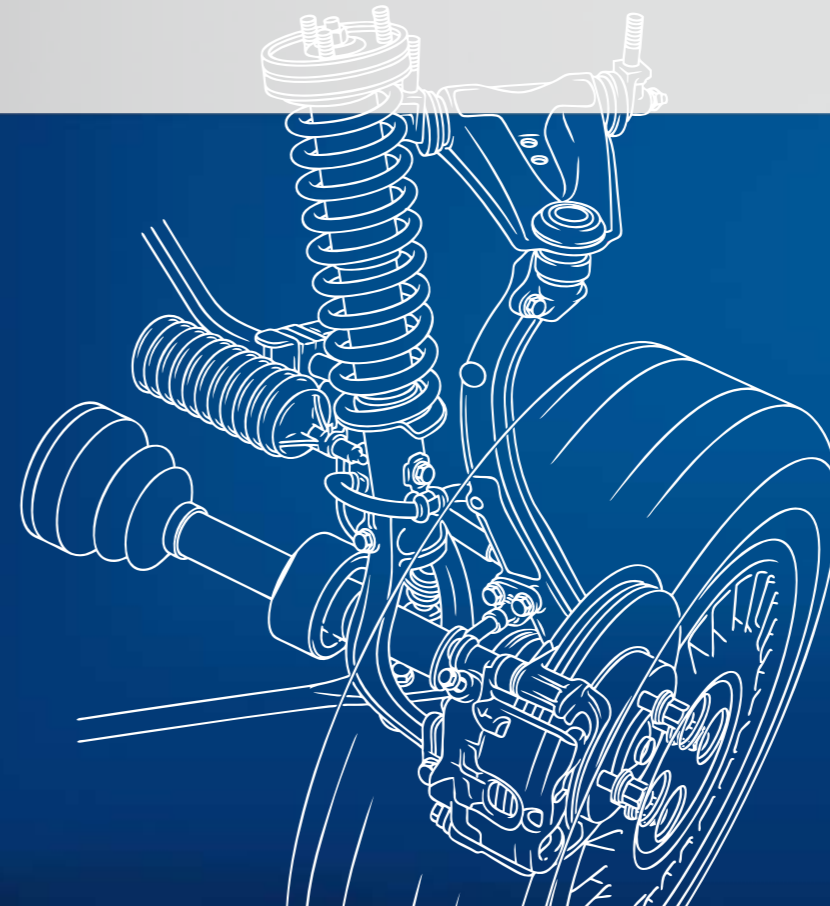

## WE HAVE BEEN SETTING NEW STANDARDS FOR GENERATIONS.

Cloths, oil and lifting platforms are just a few of the many different parts and tools our engineers use on a daily basis. They have the workshop routine down to a "T", and therefore know precisely what the professional in the field actually needs.

In a market as fast-moving and innovative as the automobile sector, we are constantly exploring and developing new opportunities. Today, every model is different, and new ideas on the drawing board call for new solutions on the road. At RUVILLE, diversity and cutting-edge technology are the keys to success – and will be for generations of spare parts to come.

Solutions geared to the requirements of the workshop – that's driving comfort right from the moment of installation.



Tapered roller bearing



1T Generation



1<sup>st</sup> Generation



2<sup>nd</sup> Generation



2.1 Generation



3E / 3EW Generation



3.2 / 3.2W Generation

Our range of products includes support joints, guide joints, track control arms, anti-roll bar links, tie rod ends and axial joints. We also supply gaiter repair kits, strut mountings and protection kits – in premium quality, of course.

Top-grade steering parts in genuine OE quality: our product portfolio encompasses around 4,000 different items covering all leading European and Asian makes and models.



## SYSTEMATIC CHASSIS EXCELLENCE: TECHNICAL HARMONY

Hundreds of tests have been performed and countless working hours invested to make sure our components are exactly tuned to each other.

Maximum performance is one of the primary requirements RUVILLE chassis parts must satisfy, as they are continuously subjected to extreme stress – whether in a passenger car or commercial vehicle. In a word: All your expectations regarding genuine original equipment quality will be met.



Strut mounting unit



A-arm axle link



Engine mounting



Support joint



Strut axial bearing



Propshaft joint repair kit



Propshaft flexible disk



Tie rod end with damper element

## AMBITION AND PERFORMANCE: THE RUVILLE SERVICE PORTFOLIO

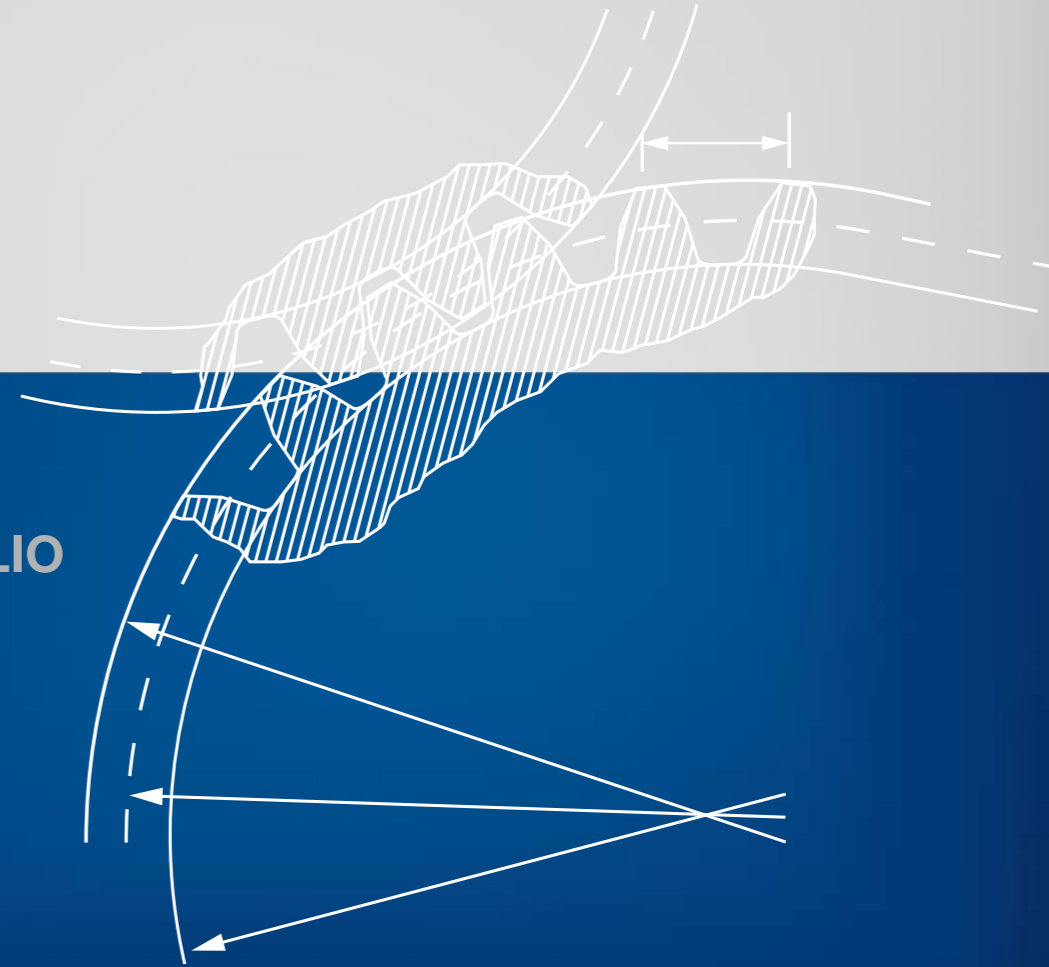

## ONE OF OUR MOST VITAL COMPONENTS HAS NO QUOTING NUMBER.

A truck fleet has to roll – 24 hours a day. And there is hardly a better way of demonstrating our reliability as your partner and as a service provider in every situation.

We understand what is needed in the field. And every RUVILLE consultant – whether in-house or in the field – is aware of each our customer's specific requirements. We are eager to meet these requirements in a practical, workshop-friendly and non-bureaucratic manner.



Try us on our promise! Our delivery service is there for you. Even though we don't have a 24/7 hotline, your orders will be shipped within one working day.

## THE SECRET OF OUR SUCCESS: COMMON SENSE

At RUVILLE, you can rely on first-class service from people who know their business inside and out. What's more, our people are totally committed to every customer project. In addition to our fully integrated SAP system, we at RUVILLE are integrated into the TecCom online ordering system and the TecDoc parts catalogue, enabling us to immediately process your order with maximum efficiency and make sure the parts you need get to you on time.



We like to share our knowledge – yet another reason for your employees and colleagues to sign up for our various specialist training programs.

The benefits are mutual: We provide you with professional training which will bring you up to speed on our state-of-the-art technology. This, in turn, helps us to get a better understanding of your needs and requirements and how to meet them.

Contact us for more information about RUVILLE's training opportunities. We look forward to hearing from you!

## 80 YEARS COMPANY HISTORY ARE ONLY THE BEGINNING.

RUVILLE – as your PARTner we look forward to taking on your challenges.

How to contact us:

### **EGON VON RUVILLE GmbH**

Billbrookdeich 112  
22113 Hamburg (Germany)

Tel.: +49 (0)40 73344-0

Fax: +49 (0)40 73344-199

info@ruville.de

www.ruville.de

